



# Wedge Wire Screen

Related products & application



# Stainless Steel Wedge Wire Screens

**Wedge wire screen panels** are composed of surface profile and support profile. The surface profile is commonly triangle wire, and the support profile can be triangle wire, wedge wire, round bar, and rectangular bar. They can suit different machines and can be used in various applications. The wedge-shaped mesh has the characteristics of high welding strength, uniform gap, high precision, corrosion resistance, long service life, and smooth surface.

**Material:** SS304, SS316L, S32750 wedge wire screen

**Support types of wedge wire screen panels.**

Triangle wire.

Round bar.

Rectangular bar.

**Wedge wire Panel Screen Standard Specifications:**

**Slot size (mm):** 0.02-50mm.

**Wire size:** 0.75\*1.5mm, 1.5\*2.5mm, 1\*2mm, 1.2\*2.3, 2\*3mm, 2\*4mm, 3\*4mm, 3\*5mm, 4.2\*6.5, 4\*7mm etc.

**Open area:** up to 60%.

Lengths up to 6 meters.

Width up to 6 meters.

**Features & Benefits:**

No-clogging Structure.

High-precision slot space & high slot opening ratio.

High abrasion and corrosion resistance.

Low-pressure drop.

Mechanical strength construction.

Bespoke specification for specific machines & uses.

Diverse apertures & profiles supplied.

Self-cleaning effect.

Smooth & flat surface.

**Applications:**

Wedge wire screen pieces have a wide range of applications, the main applications are sieving and filtration. It can also be used as decorative materials in some buildings.

Industrial filtration.

Food processing.

Petrochemical.

Mineral and aggregate processing.

Water treatment.

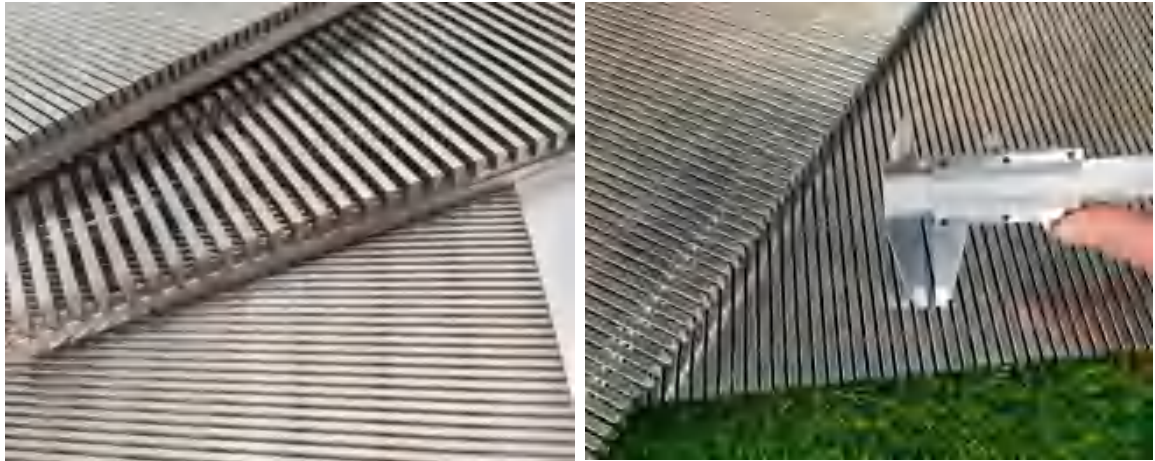

## Johnson Screen Pipe

**Johnson Screen Pipe** also be named Johnson Screen Pipe, Wedge Wire Screen Filter Pipe, Wedge Wire Screen Tubes, Industrial Screens, Water Wells, Water Well Screens and so on.

**The slot size:** 0.02mm-30mm.

















**Main material:** SS301/SS304L/316/316L/201 or other customized material.

**Opening rate:** 60%.

**Out Diameter:** 19mm-1000mm.

**Connectors Ends type:** Welding rings, Flanges, With Female&Males Threads and according to client's request.

**Length:** up to 6m.

V-Wire								
Width (mm)	0.8	1.2	1.5	1.8	1.8	2.3	3.2	3.3
Height (mm)	1.9	2.5	2.5	3.2	4.7	3.8	5.1	7.9
Relief Angle(°)	6.5°	10°	13°	10°	6°	13°	13°	8°
Support								
Width (mm)	1.8	1.8	1.8	2.3	2.3	3	3	3
Height (mm)	12.7	19	25.4	4	3.2	5	6.9	4.7



# Sieve bend screen

**Sieve bend screen** is a curved wedge wire screen filter, used for particle classification and debris filtering. Because it does not require power drive, it is also called static wedge wire screen.

**Sieve bend screen** is made by welding V-shaped stainless steel profile steel wires to vertical support rods. Then the wedge wire screen is cut and bent into a common arc (45°, 60° or other arcs) to form a curved wedge wire screen. It is suitable for removing solids from liquids or for separation of dry materials, and is ideal for screening and dewatering applications. The sieve bend screen can be made into various curvatures and apertures to adapt to different filter materials.

## Working principle

Static wedge wire screen features a continuous slot, which provides high-efficiency filtration performance. Compared with the conventional flat wedge screen, it has a larger capacity. This is because the gravity increases when the material flows to the curved surface, thereby providing higher material throughput and better filtering effect.

## Specifications of Sieve bend screen

**Material:** stainless steel wire 304, 316, 316L, 321, etc.

**Screen arc angle:** 45°, 60°, 120°, 270° and 300°.

**Wedge wire:** 0.75\*1.5mm, 1\*2mm, 2\*3mm, etc...

**Support rod:** 1\*2mm, 2\*3mm, 1.5\*2.5mm, 2\*3mm, etc... Slot size: 0.02 mm – 1 mm .

## Features

**No clogging:** The continuous slot formed by the V-shaped profile wire can ensure the minimum contact between the particles and the slot, thereby minimizing clogging.

**High filtration accuracy:** The precise slot size can meet customer requirements.

**High capacity:** The flow rate is larger than the traditional flat wedge screen.

**Easy to clean:** The screen can be easily cleaned by scraping or backwashing.

**Durable structure:** Each intersection of the profile wire and the support rod is welded to make the structure stronger.

**Low pressure drops**

## Applications

The sieve bend screen is mainly used for

Screening, dewatering, sizing and wastewater treatment applications.

Sewage treatment

Food, starch, sugar factories

Mineral processing

Pulp and paper

Textile factory



**Sieve bend screen Application:**



# Wedge Wire Filter and Strainer

**Wedge wire filter** is made of stainless steel triangular wire with continuous slot, which provides a larger opening area to filter particles and liquids. It come in two flow direction, filtering from the inside to the outside and filtering from the outside to the inside. According to customer requirements and different uses, we can design flow direction and shape to meet application requirements. We can customize various shapes of wedge wire strainer including tube, basket, cone, curved sieve bend, etc. The wedge wire filter is an ideal solution to meet the needs of industrial filtration, separation or media retention.

## Advantages

**Non-clogging:** The continuous slot of the wedge wire filter minimizes the clogging. Non-clogging provides maximum effective flow and efficient operation, thereby reducing cleaning downtime and costs.

**High precision:** Wedge wire strainer is manufactured with high precision and provide consistent slot size. The slot size can be between 0.025mm and 12.5mm, depending on the size of the particles.

**Durable Structure:** It is more durable than common wire mesh filters. Each joint of the wedge wire filters are welded to provide high strength and therefore a longer service time.

**Easy to clean:** It can be easily cleaned by scraping or backwashing.

**Design flexibility:** A variety of shapes are available, such as flat, cylindrical, conical or other shapes.



## Applications



# Wedge Wire Basket

Our **wedge wire basket** is made of stainless steel V-shaped wire and support rods. The profile wire is resistance-welded to the support rod to form a strong structure. The wedge wire screen basket is designed to be used in various centrifuges, and is the main component of a centrifugal dryer that uses high-speed or axial rotation. It has the characteristics of high strength and high precision, can withstand the stress of a centrifugal dryer, and can withstand the strong impact of particles and water. It is usually used for filtration, sieving, dehydration and classification.

**Material:** SS304/SS304L/SS316/SS316L/SS321/SS201/SS205/904L/C276, 2205, galvanized metal

**Wire shape:** Triangle, Square, Round

**Slot:** 0.02-2.0mm

**Wire size:** 0.75\*1.5mm,1.5\*2.5mm 1\*2mm,2\*3mm,3\*5mm,4\*7mm etc

**Surface treatment:** polishing Basket diameter: 500 mm, 600 mm, 800 mm, 1000 mm, 1200 mm, 1300 mm, 1530 mm and customized.

**Basket height:** 300 mm, 400 mm, 500 mm, 600 mm, 800 mm and customized.

## Features:

High load capacity

Excellent filtration performance

Efficient dehydration

Abrasion resistance

Corrosion and rust resistance

high strength

Low maintenance cost

Durable and long service life

## Applications

Screening, filtering and dewatering.

Water treatment industry: centrifugal dehydration equipment.

Mining industry

Coal industry

Oil and gas industry

fertilizer

Environmental protection





## Wedge Wire Mesh

**Wedge wire mesh** also called profile wire screen, is welded by V-wire at the top and support bar at the bottom. The finished products mainly include filter panels, filter baskets, filter elements, filter tubes and other products. It has the characteristics of uniform gap, high strength, high hardness, wear resistance, corrosion resistance, good flow rate, and easy cleaning.

**Materials:** 304, 316, 321, duplex stainless steel and other higher alloy materials.

**The gap size:** from 0.001 inches (20  $\mu$  m) to (1/2" ), providing customers with highly accurate flow distribution and effective media, debris and sediment filtering function.

**Application:**

Wedge wire mesh is used in the screening of petroleum, chemical, food and beverage, metallurgy, coal and other industries, and the filtration of water treatment is also more and more widely used in the environmental protection industry.

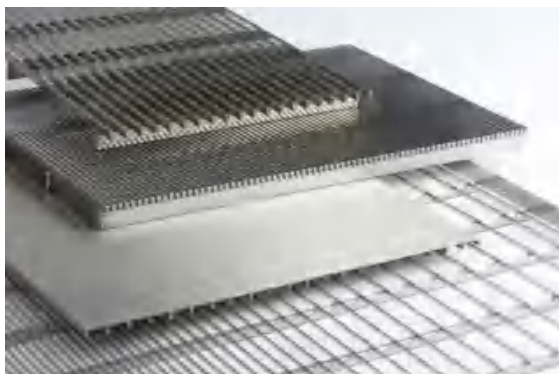
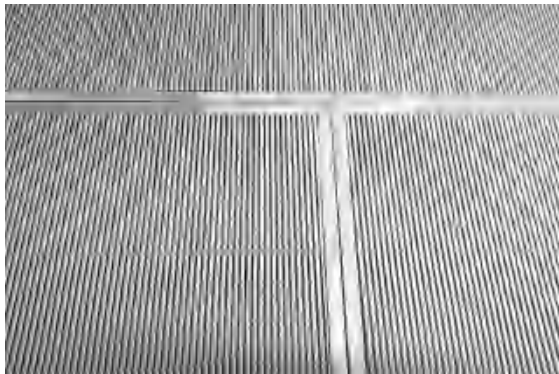

### Wedge wire mesh Application:



## Profile Wire Screen – V-Wire Screen

**Profile wire screen** also called V wire screen, as the name suggests, it is made by resistance welding V-shaped metal wire to the support rod, it has a smoother surface. From a structural point of view, this enables the V-wire screen to prevent clogging and make it have higher strength. Therefore, the profile wire screen has higher strength and durability than traditional wire mesh, porous plate or filter cloth filters.

**Filter accuracy:** ranges from 0.001 inches (20 $\mu$ m) to (1/2")

**Material:** 300 series stainless steel, such as 304, 316, 316L, 321, and two-way stainless steel and higher alloys such as 904L, Alloy 20, Hastelloy, Monel, etc.

### Application field

Machine parts, such as filtration equipment, centrifugal separators, dehydrators and vibrating screens, inflow of river water/sea water, retention of activated carbon/ion exchange resins/catalysts/filter materials, etc.

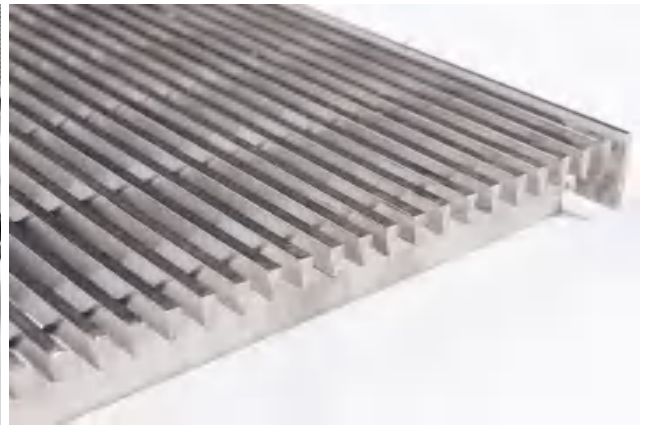
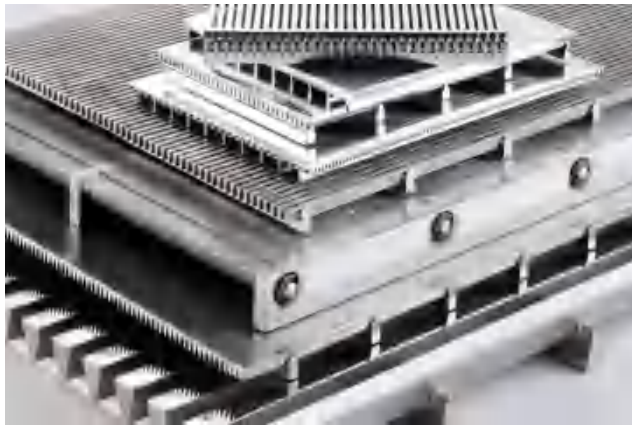

## Wedge wire cylinder tubes

**Wedge wire cylinder tubes** is a profile wire filter tube formed by welding a stainless steel V-wire around a series support bars in the circumferential direction.

**The minimum filtration accuracy** :20 microns.

**The gap between the V-wires:** can be selected between 0.02mm-60mm to meet the filtration needs of different industries.

### Features:

Wedge wire cylinder tube adopts full-process welding to form a uniform slot size. Compared with the traditional welding process, the fully welded profile wire, resin trap and screen plate have the characteristics of smooth tube surface, no burrs, and uniform gaps.

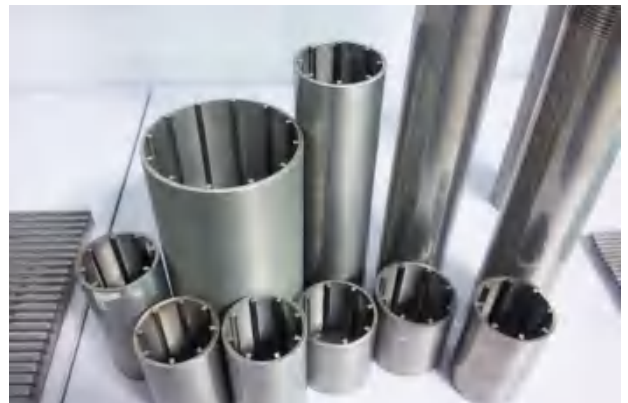



# Stainless Steel Filter Nozzles

## Stainless steel Filter Nozzle

According to the appearance, there are mainly four types of metal wedge wire nozzle, Single Head wedge wire Filter nozzle, Double Head wedge wire Filter nozzle, Single Flow rating and double flow rating filter nozzle, long handle filter nozzle.

**Material:** stainless steel 304, 316L, Hastelloy.

Commonly used standard water caps each with a flow rate of 0.5T/h, 1T/h, 1.5T/h, 2T/h, 3T/h, 5T/h.

The installation joint has external thread connection and internal thread connection, with standard thread and non-standard customized.

## Stainless Steel Filter Nozzles Characteristics:

1. Typical slot opening ranging from 0.02-5mm, the gap is uniform and not easy to be blocked
2. Threaded end flange or "L" bolts.
3. Primarily made of stainless steel, anti-corrosive and long service life.
4. Continuous slot design provide large circulation area
5. The surface of the goods is polished, not easy to rust, strong and durable.
6. Easy to use, easy to install and replacement.

## Stainless Steel Filter Nozzles Application:

Water Filter Nozzles are used for liquid and solid separation or gas and solid separation, and are designed with their quality and performance in mind. It is commonly used as a connector and configurator in desalination plants, water softeners, and pressure and gravity sand filters.

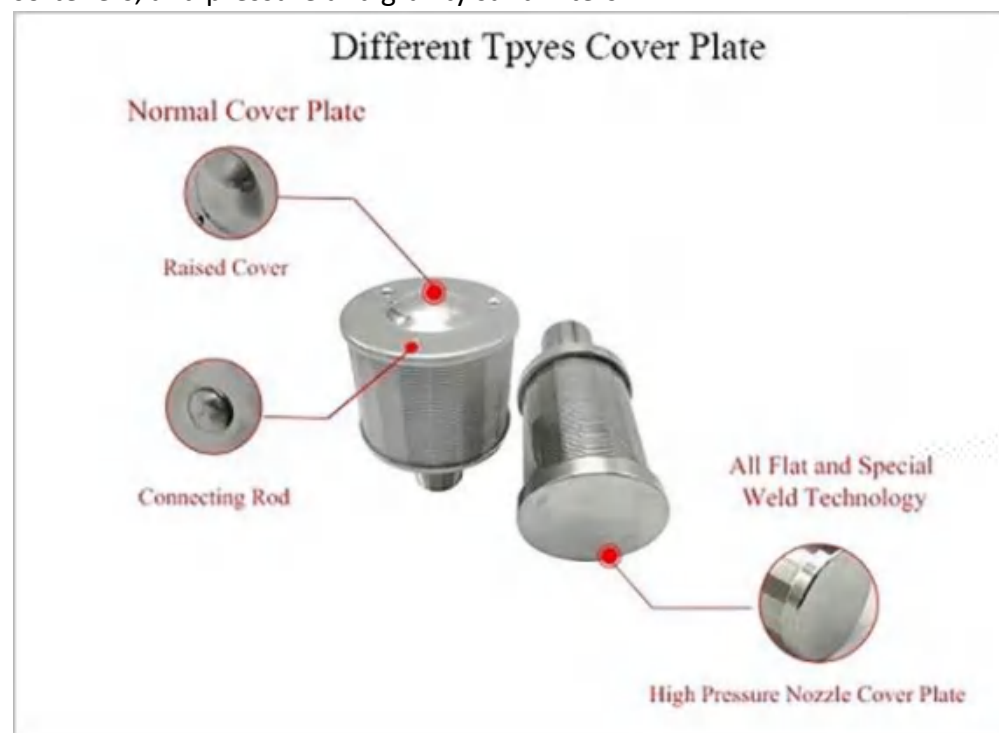

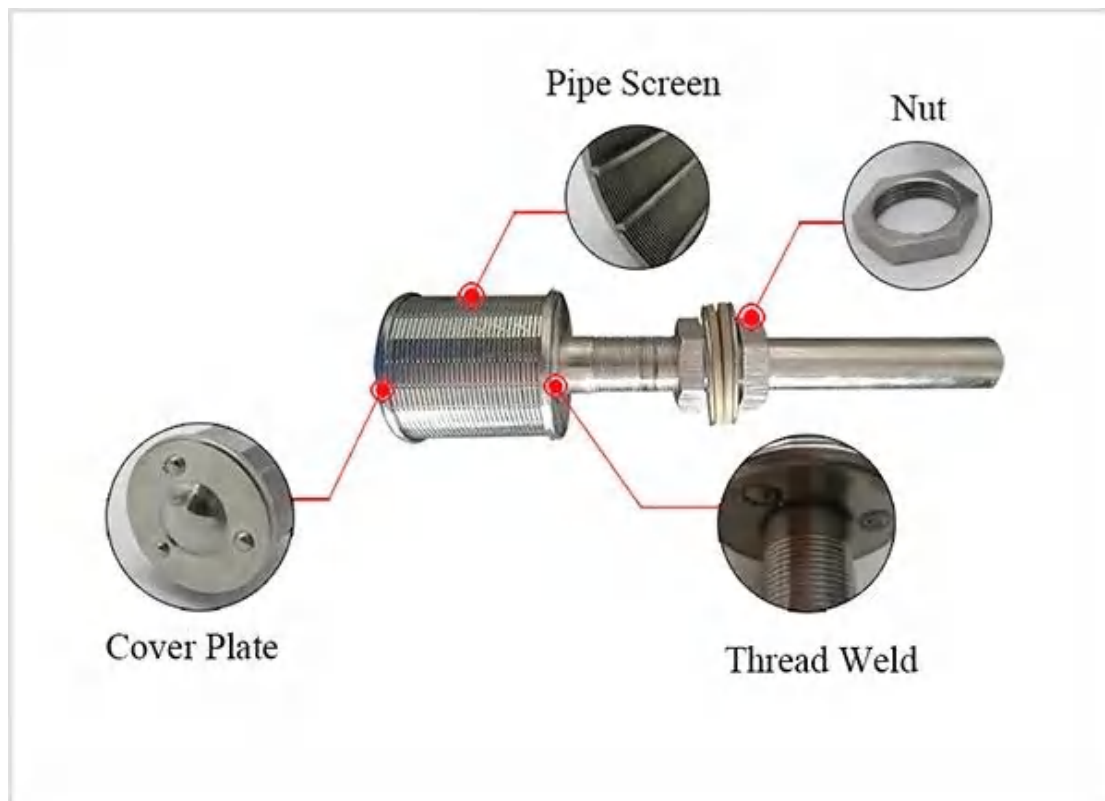

#### **Stainless Steel Filter Nozzles Advantages:**

1. Optimum structural strength for heavy loads
2. Minimal plugging and blinding
3. High pressure/pulsating pressure capability
4. Corrosive application suitability
5. Thermal resistance
6. Long-life — almost endless cleanability
7. Sterile application/food industry suitability
8. Low-pressure drop
9. High flow rate
10. We can supply all kinds of filter nozzles, and the material and size can be customized. We can design according to the actual application.

Single wedge wire nozzle



Double wedge wire nozzle



**Equipment Structure**

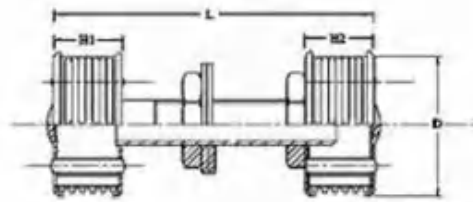
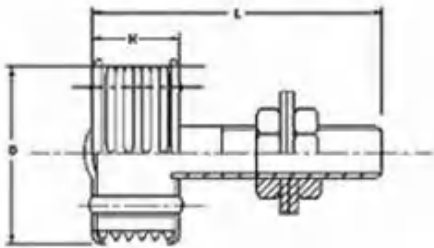

# Wedge Wire Trommel Screen

**Wedge Wire Trommel Screen** also called wedge wire filter drum. The drum screen is the core component of the manure separator, made of wedge wire screen, its design directly affects the efficiency and service life of the separator. The product specifications required to handle different manure are different.

Our Single Trommel Drum Wastewater Screen to help reduce industrial waste and increase product recovery. Efficiently performs liquid/solid separation for red meat, pork, poultry, seafood or vegetables. Wedge-wire screens offer greater cleaning efficiencies, or reduce water requirements with an optional.

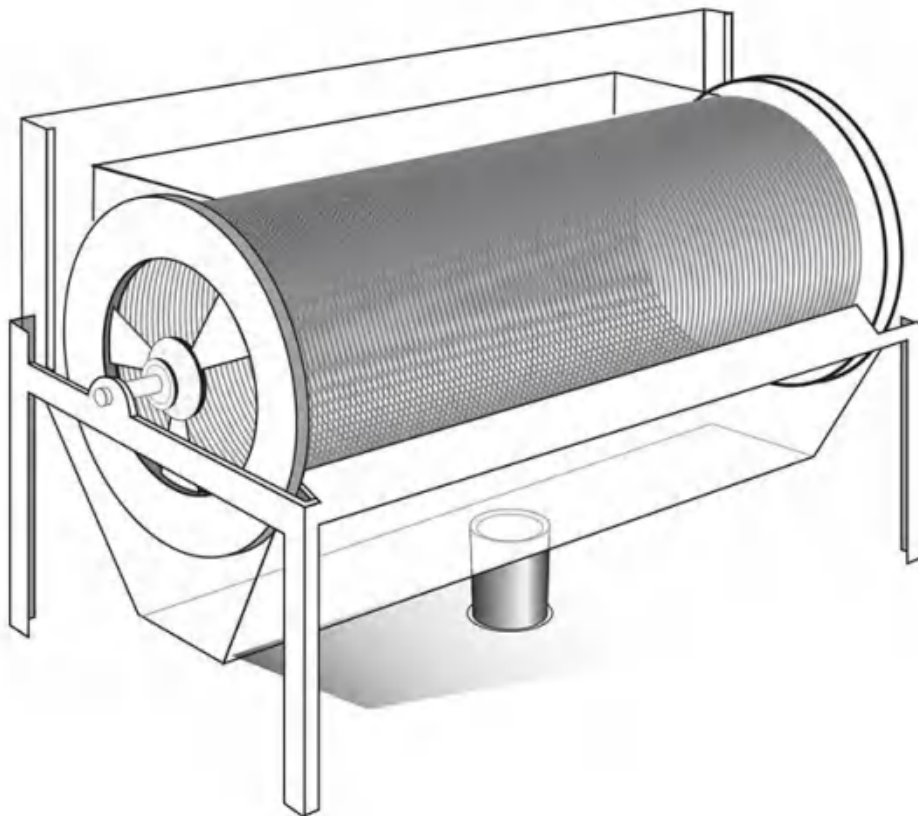

## **Application:**

For special areas of application (among others, the starch industry) screen cylinders can of course also be manufactured in looped finish.

## **Advantage:**

High screening rate, abrasion resistance, corrosion resistance, anti – slip, anti – vibration, strong elasticity, toughness, not close. The mesh section is trapezoid or wedge. There's room in the gap. It is made of stainless steel wire cold rolled screen, support bar is welded by automatic production equipment, screen seam uniform, stable welding quality, high porosity, long service life, high strength, steel degree and bearing capacity, can be made into various shapes

of screen filter device.

**Working Principle:**

The Trommel Screen is mounted obliquely on the frame. The motor is coupled to roller device via the reducer and drive the drum rotates around its axis.

When the material enters the drum screen, due to the inclination and rotation of the roller device, the material on the screen surface will turn over and roll, so that the qualified material will be discharged through the outlet at the bottom of the drum, and the unqualified material will be discharged through the outlet at the end of drum.

Due to the overturning and rolling of the material in the drum, the material stuck in the screen hole can be ejected to prevent the screen hole from blocking.

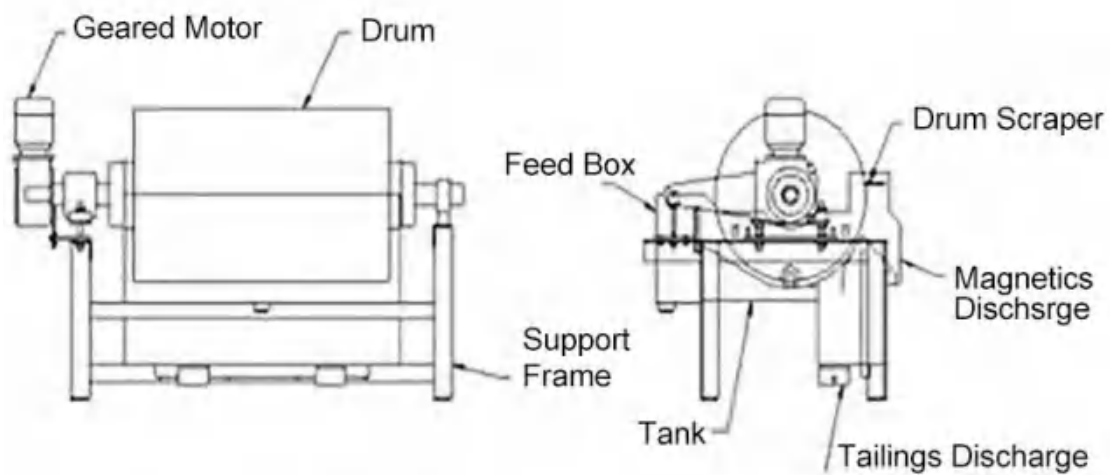

General Arrangement of a Typical Wet Drum Separator



